

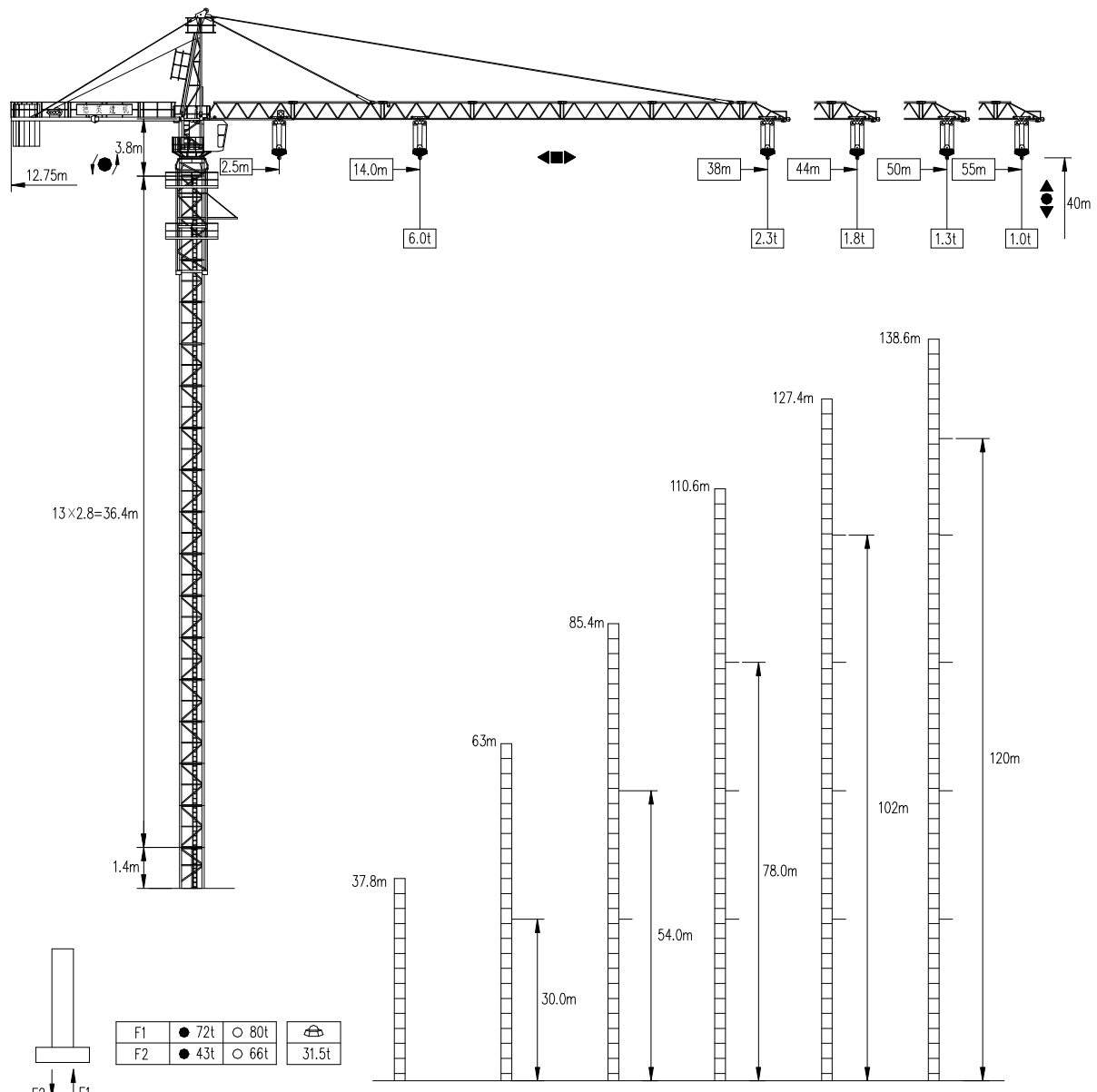

# Tower Crane TC5510

## TC5510 6t

DEYING®  
德英





F1	● 72t	○ 80t	
F2	● 43t	○ 66t	31.5t

F2 ↓    ↑ F1



F 反力    Reaction	● 工作状态    in service	自重    without load and ballast with the longest jib and maximum height
	○ 非工作状态    out of service	

## 载荷特性 Load Capacity



起重臂 jib (55m)

R (m)	2.5-14.00	17	19	21	23	25	28	30	32	34	36	38	40	42	44	46	48	50	52	55
Q (t) 	6.00	4.41	3.88	3.45	3.10	2.80	2.44	2.25	2.07	1.92	1.79	1.67	1.55	1.43	1.37	1.29	1.22	1.15	1.09	1.00
Q (t) 	3.00					2.86	2.50	2.31	2.13	1.98	1.85	1.73	1.61	1.46	1.43	1.35	1.28	1.21	1.15	1.06



起重臂 jib (50m)

R (m)	2.5-14.16	16	18	20	22	24	26	28	30	32	34	36	38	40	42	44	46	48	50
Q (t) 	6.00	5.22	4.56	4.04	3.62	3.27	2.97	2.72	2.50	2.31	2.15	2.00	1.87	1.75	1.64	1.54	1.46	1.37	1.30
Q (t) 	3.00							2.78	2.56	2.37	2.21	2.06	1.93	1.81	1.70	1.61	1.52	1.43	1.36



起重臂 jib (44m)

R (m)	2.5-15.88	18	20	22	24	26	28	30	32	34	36	38	40	42	44
Q (t) 	6.00	5.20	4.62	4.14	3.74	3.41	3.13	2.88	2.67	2.48	2.31	2.16	2.03	1.91	1.80
Q (t) 	3.00							2.94	2.73	2.54	2.48	2.21	2.08	1.92	1.86

起重臂 jib (38m)

R (m)	2.5-16.66	18	20	22	24	26	28	30	32	34	36	38
Q (t) 	6.00	5.50	4.88	4.38	3.96	3.61	3.31	3.05	2.83	2.63	2.46	2.30
Q (t) 	3.00							2.89	2.69	2.52	2.36	

## 机构特性 Mechanism specification

起升 Hoisting 							KW N.m		
	m/min	80	40	9	40	20			4.5
	t	1.5	3.0	3.0	3	6.0			6.0

变幅 Trolleying 	m/min	40/20	3.3/2.2
---	-------	-------	---------

回转 Slewing 	r/min	0~0.6	2x2.2 (2x55)
--	-------	-------	--------------

顶升 Climbing 	m/min	0.6	5.5
---	-------	-----	-----

供电容量 Necessary electric power	37.2
-------------------------------	------

电源 Main supply	~380V/50Hz
----------------	------------

臂长 Jib length (m)	55	50	44	38
平衡重 Counterbalance (m)	13.5	12.0	10.2	9.1

**固定式** Stationary

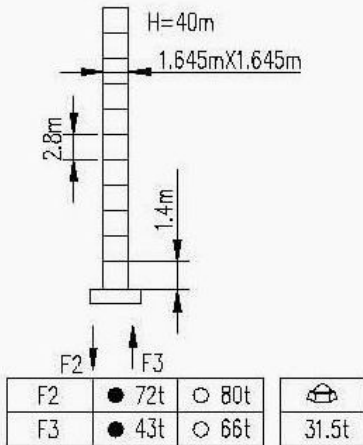

**内爬式** Internal climbing

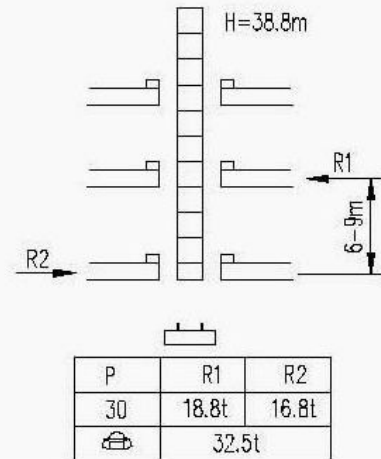

**Main Technical Parameter**

Item		Unit	Parameter			
Metric lifting moment		KN.M	630			
Max. lifting capacity		T	6			
Tip load capacity		T	1			
Working radius		M	2.5~55			
Hoisting Height	Independent	M	40			
	Attachment	M	138			
Hoisting Speed	Fall		2		4	
	Hoisting Speed	M/min	0~40	0~80	0~20	0~40
	Max Lifting Capacity	T	3.0	1.5	6.0	3.0
Slewing Speed		R/min	0~0.6			
Trolleying Speed		M/min	40/20			
Climbing Speed		M/min	0.56			
Weight	Independent Structure	T	30.0			
	Counter-Balance	T	12.50			
	Stationary Structure	T				
Max. Slewing Radius		M	50			
Counter-Jib Slewing Radius		M	12.75			
Max. Working Wind Speed		M/s	20			
Climbing Wind Speed ≤		M/s	13			
Working Environment Temperature		°C	-20~+40			



## Tower Crane Electronic Parts

Creepage recloser	Breaker	Plastic shell breaker	Main AC contactor	Schneider electric
Relay	Time relay	Medium relay	Bridge unit	
Transducer	Moment spacing swish	autotransformer	Coder feekback	
DC power supply	Kenotron	Avail adapter socket	Retainer adapter	

## Main Parts Parameter

Item				Parameter
Hoisting Mechanism	Electromotor	Model		YZTD225L <sub>2</sub> -4/8/32
		Power	Kw	24/24/5.4KW
	Reducer	Model		JD566
	Steel rope			12NAT6X19W
Slewing Mechanism	Electromotor	Model		YTLEJ112L-55-4
		Power	N.m	2x55
		Turning rate	R/min	960
	Reducer	Model		XX4-80.195C
Trolleying Mechanism	Electromotor	Model		YDEJ132S-4/8
		Power	Kw	8
		Turning rate	R/min	700/1450
	Reducer	Model		BXJ45
		Speed Ratio		i=45
	Steel rope			8NAT6X19W
		Power	Kw	5.5
	Hydraulic pump	Cylinder model		HSGK01-169/110BE
		Route of travel	mm	1600
	Discharge of Hydraulic pump		L/min	11
Working Pressure		MPa	20	

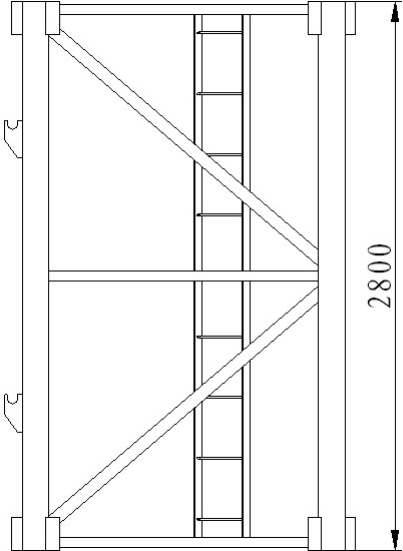
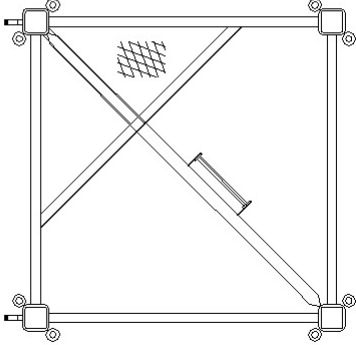
## Main Metal Parts List

	
<p><b>Mast Section</b></p> <p>The mast composition consists of a quantity of standard sections. The number of standard sections is determined by the height of the crane. Standard section consists of main chord, horizontal brace and tilting brace, which are welded to a spatial trussing. The length of each standard section is 2.8m, the section size is 1.645×1.645m</p>	<p><b>External Dimensions</b>  1645×1645  Overall Height:2800</p>
	
<p><b>Jib</b></p> <p>The hoisting jib is non-uniform section and isosceles triangle type, the upper and lower chord is a square tube welded by two angle bars, the tilted brace and horizontal brace are made of seamless tube. Both the upper and the outside surface of the lower chord are kept horizontal and vertical, thus, the lower chord can also be used as a rail for jib trolley</p>	

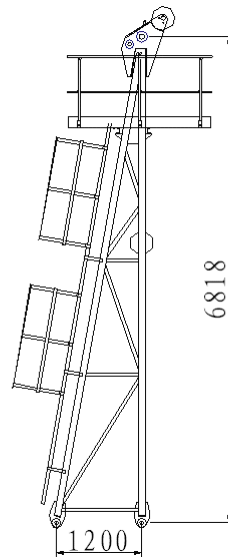

### Tower Cap

The cat head is a triangular spatial trussing. The front and rear chord is welded as a square tube by two angle bars, the brace of which is made of the seamless tube. Its bottom is connected with the slewing tower by pin roll. The front and rear side of which are installed with pulling plates that hinged to tie bar of the hoisting jib and the counter jib respectively. The upper part of the cat head has a platform, the installation person can stand on it to disassemble the crane and thread the hoisting wire rope.

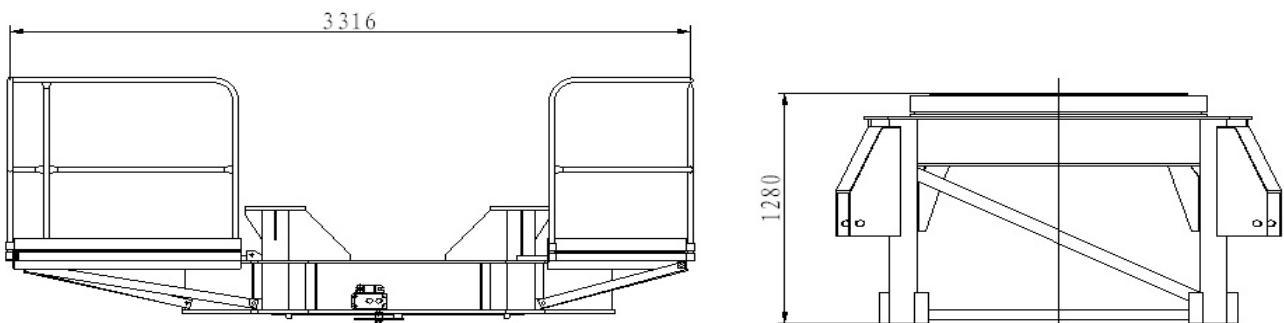

Upper and lower pedestal are case structure welded by plate.

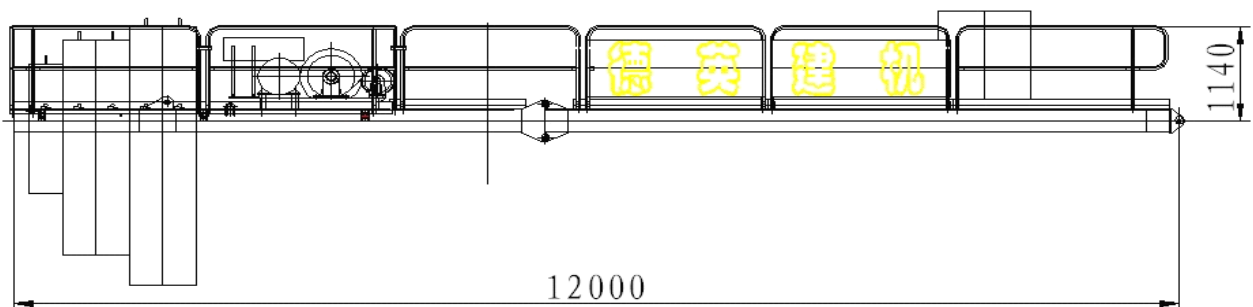

### Counter jib

The counter jib is a spatial trussing composed of four angle bars. The hoisting mechanism locates at the rear of the counter jib and the counter blocks are located at the tail.

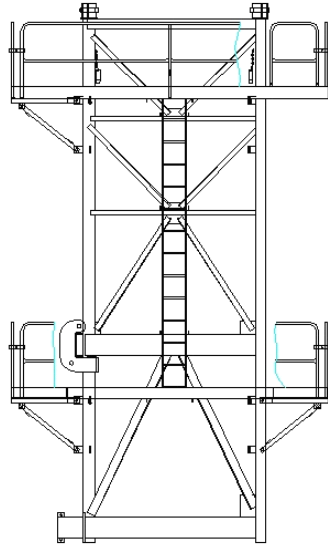

### Frame

Space frame structure welded by channel steel, angle steel and steel board

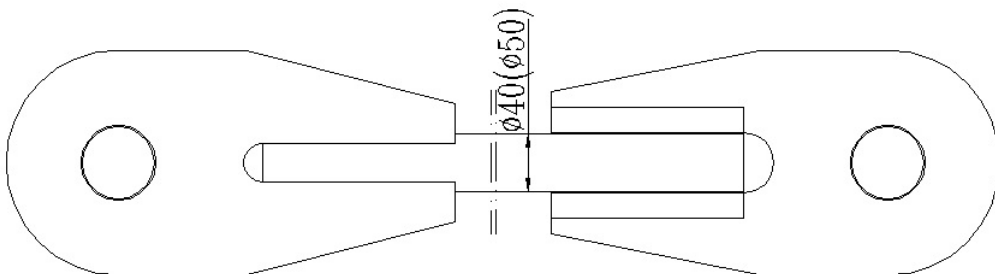

### Jib Tie Bar

Tie bar of the jib is welded by the solid round steel.