

Tower Crane TC6015A

TC6015A

8t

DEYING®
德英

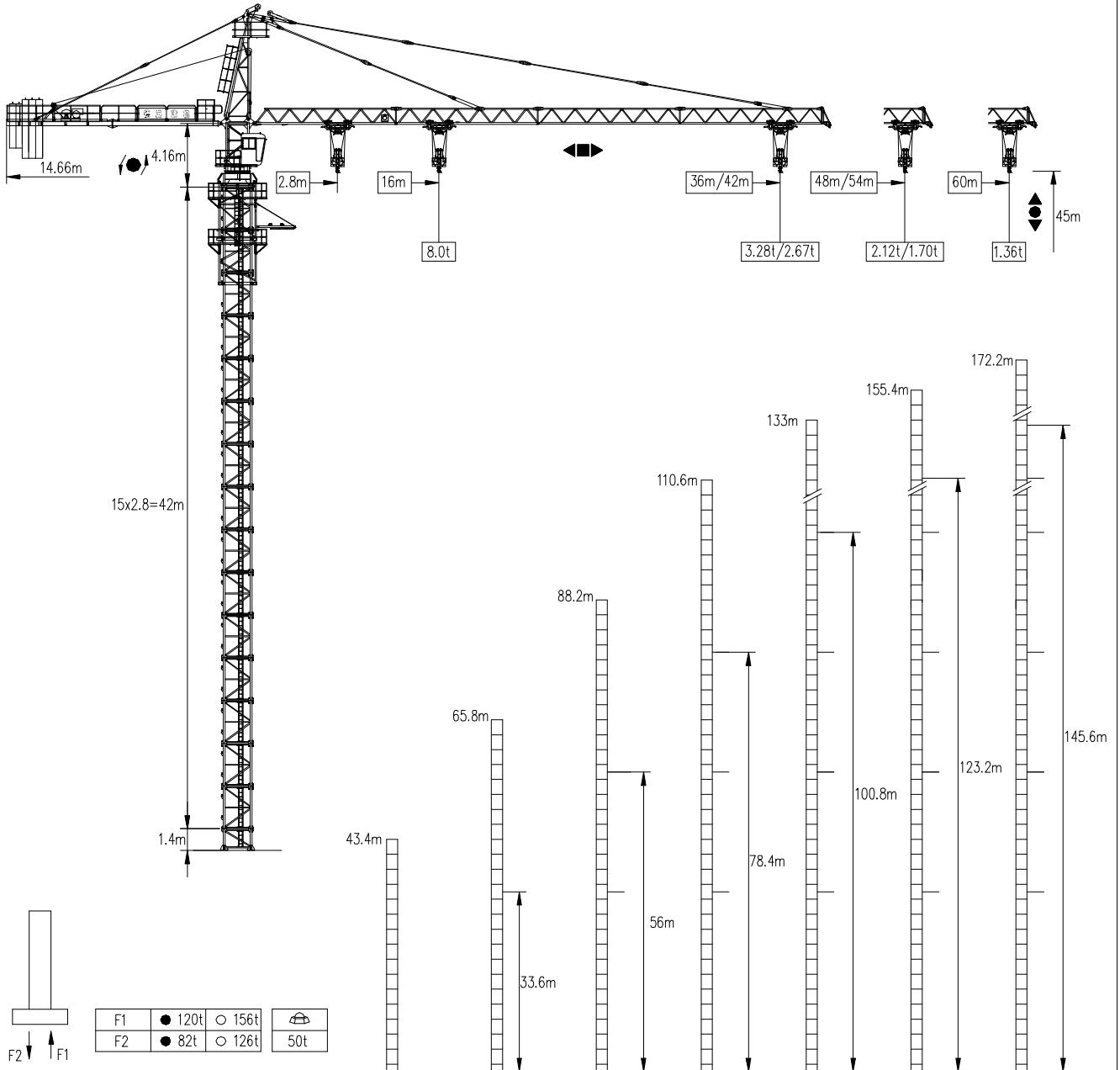

F 反力 Reaction	● 工作状态 in service	自重 without load and ballast with the longest jib and maximum height
	○ 非工作状态 out of service	

内爬式 Internal climbing

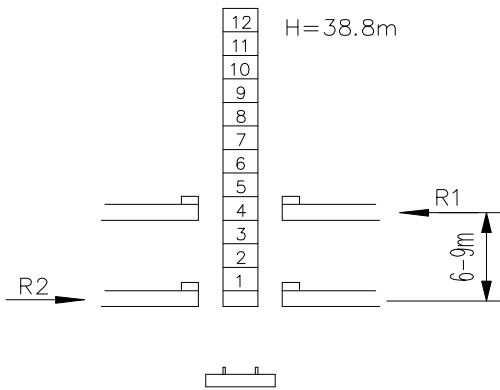

P	R1	R2
30	18.8t	16.8t
	32.5t	

固定式 Stationary

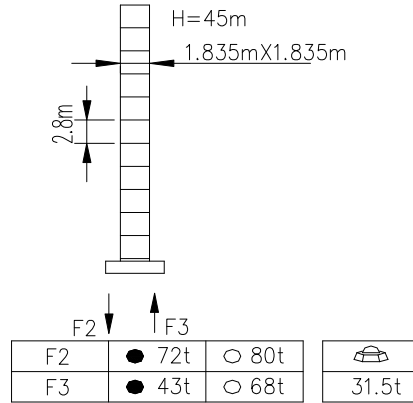

For other type, depending on customers' requirements

Jib length 60m

Radius(m)	Multiple ratio	2.8 ~ 16.0	20	25	28.2	30	36	42	48	54	60
Payload capacity (t)	4	8.00	6.13	4.66	4.00	3.70	2.91	2.35	1.94	1.62	1.40
	2	4.00				3.77	2.98	2.42	2.01	1.69	1.50

Jib length 54m

Radius(m)	Multiple ratio	2.8 ~ 16.5	18	20	29.2	30	36	42	48	54
Payload capacity (t)	4	8.00	7.23	6.37	4.00	3.86	3.04	2.46	2.03	1.70
	2	4.00				3.93	3.11	2.53	2.10	1.77

Jib length 48m

Radius(m)	Multiple ratio	2.8 ~ 17.0	18	20	25	30	36	42	48
Payload capacity (t)	4	8.00	7.47	6.58	5.02	4.00	3.16	2.56	2.12
	2	4.00					3.23	2.63	2.19

Jib length 42m

Radius(m)	Multiple ratio	2.8 ~ 17.5	18	20	25	30.9	36	42
Payload capacity (t)	4	8.00	7.73	6.82	5.21	4.00	3.28	2.67
	2	4.00					3.35	2.64

Jib length 36m

Radius(m)	Multiple ratio	2.8 ~ 17.5	18	20	25	30.9	36
Payload capacity (t)	4	8.00	7.73	6.82	5.21	4.00	3.28
	2	4.00					3.35

I. Main Technical Parameter

Item		Unit	Parameter			
Metric lifting moment		KN.M	1280			
Max. lifting capacity		T	8			
Tip load capacity		T	1.5			
Working radius		M	2.8~60			
Hoisting Height	Independent	M	45			
	Attachment	M	174			
Hoisting Speed	Fall		2		4	
	Hoisting Speed	M/min	0~40	0~80	0~20	0~40
	Max Lifting Capacity	T	4.0	2.0	8.0	4.0
Slewing Speed		R/min	0~0.6			
Trolleying Speed		M/min	45/23/6			
Climbing Speed		M/min	0.56			
Weight	Independent Structure	T	55.0			
	Counter-Balance	T	19.0			
	Stationary Structure	T				
Max. Slewing Radius		M	60			
Counter-Jib Slewing Radius		M	14.66			
Max. Working Wind Speed		M/s	20			
Climbing Wind Speed ≤		M/s	13			
Working Environment Temperature		℃	-20~+40			

II. Tower Crane Electronic Parts

Creepage recloser	Breaker	Plastic shell breaker	Main AC contactor	Schneider electric
Relay	Time relay	Medium relay	Bridge unit	
Transducer	Moment spacing swish	autotransformer	Coder feekback	
DC power supply	Kenotron	Avail adapter socket	Retainer adapter	

III. Main Parts Parameter

Item			parameter	
Hoisting mechanism	Electromotor	Model		YZRDW250L-4/8-37/37
		Power	Kw	37
		Turning rate	R/min	1460/730/150
	Brake	Model		YWZ-315/90
		Braking moment	N.m	630
		Hydraulic braking		Hydraulic braking
	Reducer	Model		JD630
		Speed Ratio		i=17.6
	Steel rope			14NAT6X19W
Slewing mechanism	Electromotor	Model		YZR132M ₁ -6
		Power	Kw	2×4.0 (2x75)
		Turning rate	R/min	975
	Reducer	Model		XX4-80.195C
		Speed Ratio		195
	Brake			Moment Brake
	Slewing ring bearing			011.45.1400.001
Trolleying mechanism	Electromotor	Model		YLEW112M-6
		Power	Kw	60
		Turning rate	R/min	700/1410
	Reducer	Model		SX308
		Speed Ratio		i=33.66
	Steel rope			8NAT6X19W
Hydraulic climbing mechanism	Electromotor	Model		M2QA132M4A
		Power	Kw	7.5
		Turning rate	R/min	1440
	Hydraulic pump	Cylinder model		TQY80
		Route of travel	mm	1600
	Discharge of Hydraulic pump		L/min	14.4
	Working Pressure		MPa	28

IV. Main Metal Parts List

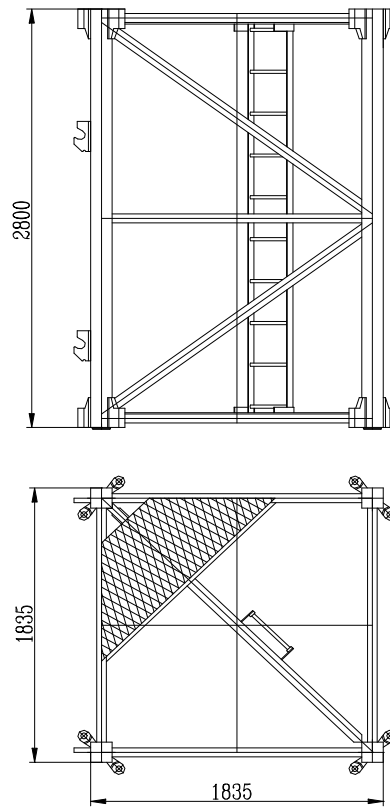

Mast Section

External Dimensions

Main Chord
 $\angle 12 \times 135 \times 135 \text{mm}$

1835×1835
 Overall Height:2800



Jib

Total 9 Sections
 Jib section connected through pin

Tie-in of jib is processed after forging and it has small diastema and the jib has good rigidity.